

# Silicone Rollers

Hot Stamping Supplies

ITW Imtran's rubber rollers are the ideal choice for peripheral decorating of cylindrical shapes and roll-on decorating of large flat or curved surfaces. The rubber conforms readily to surface variations in molded plastic parts, ensuring smooth application of hot stamping foils and multi-color heat transfers. Silicone rubber rollers are used in a variety of applications including banding, laminating, printing and decorating. Carefully engineered and crafted, our rollers are specifically matched to the application.



## Silicone Rubber

Formulations

- Supersil™ ( Red ), Standard
- Recotech™ ( Blue )
- Ultrasil™ ( Red )

**Hardness- Measured using a Shore A scale**

- 60 & 70 durometer, standard
- 40 - 90 durometer available

## Roller Specifications

Outside Diameter (A)  
Rubber Thickness (D)  
Face Length (E)

## Metal Core

Material

- Aluminum, standard
- Steel

Core Diameter (B)

Bore Diameter (C)

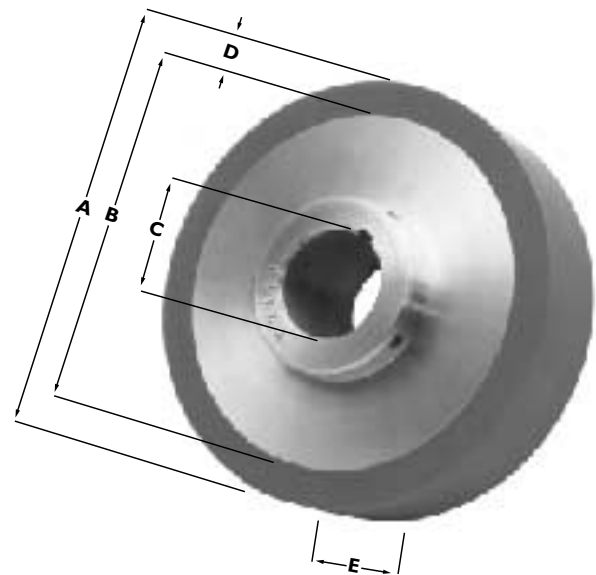

## Common Applications

- Heat Transfer & Hot Stamping
- Extruded Product
- Heat Sealing
- Edge Banding
- Cylindrical Shapes
- Packaging
- Laminating
- Feed & Guide Rollers
- Linerless Labels

**ITW Imtran**

An ITW Decorating Company

ITW Imtran  
An ITW Decorating Company  
39 Shelley Road  
Haverhill, MA 01835  
Phone: 978.372.3443  
Fax: 978.372.9817  
Website: [www.itwimtran.com](http://www.itwimtran.com)

Pad Printing Equipment: Standard machines, multi-color, automated systems.  
Pad Printing Supplies: Cliches, ink, silicone pads, part holding fixtures.  
Hot Stamping Supplies: Silicone rubber dies, rollers, sheets, metal dies, makeready material.